



TP-1603

TOUCH PAD LOCK

The larger model of the TP-1602, the TP-1603 is a medium frame TouchPad Lock compatible with a range of OLP's locker range. With a minimalistic design, the TP-1603 lock is usable in both public and private settings, with a simple twist to open design.

1300 272 657
OLP.COM.AU



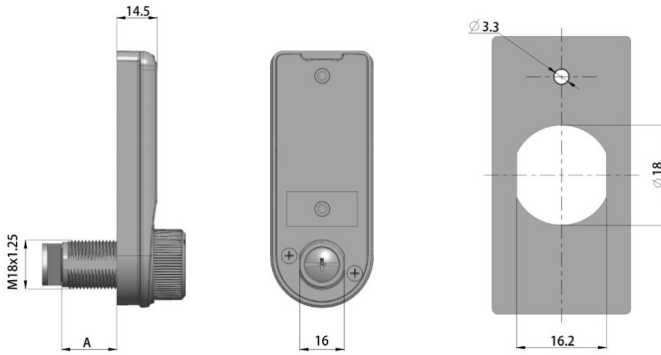

PRODUCT INFORMATION

FEATURES

- Simple TouchPad unlock functionality
- Twist to open design
- Codes between 4 and 15 digits long
- Lock status indicator (Locked and unlocked)
- Backlight display with clear numbers
- Powered by 1x CR2032 coin battery (not included) ~2,000 uses
- Interchangeable between public and private modes
- 16mm, 20mm or 30mm cylinder length available
- External micro USB power port
- 1-year product warranty
- Lock requires Button style battery – please see warning below.

LOCKER COMPATIBILITY

	COMPATIBLE	NOT COMPATIBLE
Laminate Locker	•	
ABS Plastic Locker		•
HD Plastic Locker	•	
HD Waterproof Locker		•
Carousel Locker		•
Mobile Phone Locker		•
Laptop Locker		•
HD School Locker		•
Steel Locker	•	

TECHNICAL SPECIFICATONS

LOCK CODE	LOCK NAME
LKWT 1603TP	TP-1603 Touch Pad Lock

WARNING

KEEP OUT OF REACH OF CHILDREN

Swallowing can lead to chemical burns, perforation of soft tissue, and death. Severe burns can occur within 2 hours of ingestion. Seek medical attention immediately.

